

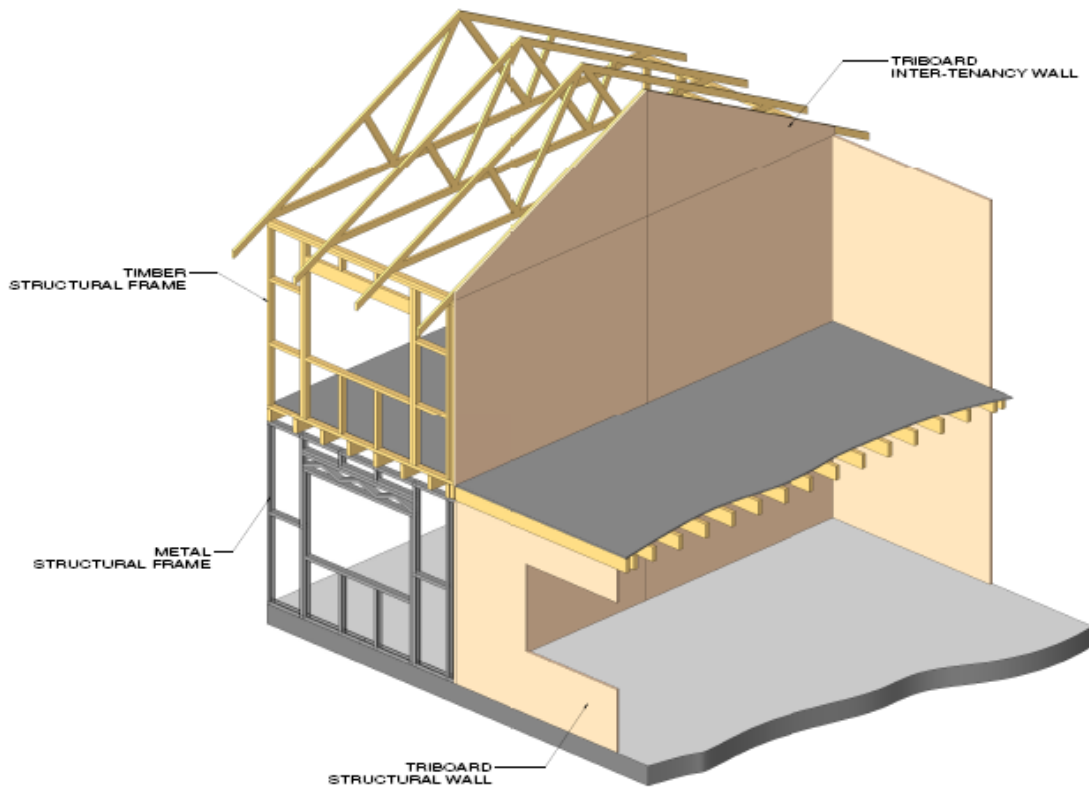

TRIBOARD INTER-TENANCY WALL SYSTEM



A brief history of Triboard development

Before Triboard was developed in the mid 1980s there were primarily three different types of reconstituted wood panel products that were generally available; namely particleboard, MDF (medium density fibreboard) and OSB (orientated Strandboard).

Particleboard developed in post war Europe and was used for furniture, benchtops and other similar uses.

MDF was first produced in the United States of America in the mid 1960s and became the material of choice where a fine smooth finish was important.

OSB was developed in North America as a structural panel to offer an alternative to plywood, and by the 1980s was well established in wall sheathing and roof sarking applications.

The innovation which became Triboard was to form up and press a three layered wood panel product with an MDF surface on both sides of a random orientated Strandboard core.

The Juken New Zealand Ltd Triboard Mill, at Kaitaia in the north of New Zealand, commenced production in 1987.

Triboard Mill manufactures a wide range of reconstituted wood panel products in a variety of thicknesses and densities. For further information visit our website at www.triboard.com

Juken New Zealand Ltd operates a Quality Management System that complies with the requirements of ISO 9001 and an Environmental Management System that complies with the requirements of ISO 14001. Both systems are assessed and certified by SGS Systems & Services Certification PTY Ltd.

Scope

The Triboard Inter-tenancy Wall System has been designed for use as load bearing or non-load bearing fire rated and sound insulating straight walls.

The Triboard Inter-tenancy wall System, when constructed in accordance with this Manual, can achieve a Fire Resistance Rating (FRR) of 60/60/60 and an STC rating of 56.

The Triboard Inter-tenancy Wall System is suitable for use when interfacing with:-

- Traditional timber frame construction.
- Light gauge steel frame construction.
- Triboard construction.

The Triboard Inter-tenancy Wall System is suitable for use as infill panels within buildings having concrete frames designed to NZS 3101.

For loaded walls, the maximum allowable design load is 20 kN/m of wall length.

The maximum height allowed for a Triboard Inter-tenancy Wall System is 3.0 metres for loaded walls and 4.5 metres for unloaded walls.

It should be noted that the wall heights referred to above are deemed to be from floor level to ceiling level of any single storey within a building.

Loaded walls greater than 3.0 metres in height and with loads greater than 20kN/m are outside this scope and will require specific design.

The use of Triboard wall panels in the following situations is outside this scope:-

- In sauna rooms and the like where they may be exposed to sustained high humidity (greater than 95% RH) or liquid water.
- Where temperatures are in excess of 35°C over large areas for prolonged periods or in excess of 50°C in localised areas (e.g. the area adjacent to a fuel burning appliance).

This scope should be read in conjunction with BRANZ Appraisal Number 593 (2008).

Description of Inter-tenancy Wall System

General

- The Triboard Inter-tenancy Wall System is comprised of two separate layers of 38mm thick Triboard separated by a 100mm wide cavity.
- The Triboard panels used in the Triboard Inter-tenancy Wall System measure 4.00m by 2.45m.
- Each Triboard panel is stiffened with 45mm x 45mm timber battens facing into the cavity.
- The cavity is filled with sound control infill material.
- The wall panel perimeter is sealed with fire sealant.

Triboard panels

- The Triboard panels are manufactured and supplied by Juken New Zealand Ltd.

Timber battens

- Battens are full height kiln dried MSG8 45mm x 45mm H1.1 treated timber located at 600mm vertical centres and screw fixed to the Triboard panel from the batten side with 75mm x 10 gauge steel screws spaced as detailed on the drawings in this Manual.
- Batten locations on opposing wall panels are staggered.
- The battens must have a moisture content of no more than 18% at the time of fixing to the Triboard panels.

Connections

- The Triboard panels are located and connected to the structure at top and bottom panel edges by 40mm x 30mm x 1.2mm folded galvanised steel angles screw fixed to the Triboard panels at 200mm centres with 30mm x 10 gauge steel screws.
- The folded galvanised steel angles are gun nailed to concrete structures with 30mm x 3.5Ø nails at 200mm centres.

Joints in Triboard panels

- Joints between adjoining panels are formed by stepped edges with each panel edge rebated to form a 10mm step.
- Vertical joints are backed by a full height 100mm wide strip of 38mm thick Triboard.
- The Triboard strip is screw fixed from behind using 65mm x 10 gauge steel screws as detailed in the drawings in this technical literature.
- Panel joints are staggered on opposite sides of the wall and should not occur within 900mm of a joint on the opposite leaf, except that horizontal joints in non-load bearing walls may occur adjacent to each other.
- Horizontal joints have the same 100mm wide strip of Triboard, but instead of being continuous it spans between the vertical battens.
- For walls more than 2.45m high, the panels should be used on end such that the vertical joints are spaced at 2.44m (i.e. 2.45m panel width less 10mm for the step).
- For walls more than 4.0m high, the horizontal joint should be at the 4.0m line with a filler piece above to take the wall to the required height.

Wall to ceiling junctions

- Gib Fyreline® and Gib Plaster Cove® materials are used to achieve the fire rating and they should be installed according to their manufacturers requirements.

Sound Control Infill

- The sound control insulation used in the Triboard Inter-tenancy Wall system is 75mm thick Noise Control Blanket manufactured by Tasman Insulation New Zealand Ltd.

Finishing of walls

- Triboard Inter-tenancy Wall panels must be finished with a paint system or clear finish or wallpaper or similar.
- Triboard Inter-tenancy Walls may also be battened out for other internal linings, e.g. to accommodate services.
- If wall panels are to be painted or clear finished they can be done so by using either water based or solvent based products, but the coating manufacturers recommendations must be fully complied with.
- Prior to painting or clear coating, all dust should be removed from the surface of Triboard panels.
- If the wall is to be wallpapered, the wall should be sealed first with an acrylic or alkyd based sealer.

Stopping of joints between panels

Joints between panels may be stopped using normal plasterboard materials as follows:-

- The Triboard must be dry before stopping or the stopping will crack. If the Triboard has got wet for any reason, do not stop the joints until the moisture content of the Triboard is 15% or less.
- Both panel edges should be bevelled to approx 3mm deep by 50mm to 75mm wide.
- Use bedding compound to fix paper tape (not glass tape).
- Finish with finishing compound.

Wall lining in wet areas

- All Triboard surfaces in areas likely to be wetted on a regular basis should be protected from moisture by fitting a separate wall lining material designed for the purpose.

Maintenance

- The building must be maintained in a weathertight condition and all components of the Triboard Inter-tenancy Wall System must be protected from internal and external moisture.
- The internal linings or finishing must be maintained to provide protection to the Triboard Inter-tenancy Wall System from internal moisture.
- Regular inspections (at least annually) of the external cladding system and the internal linings and finishes must be made and any damage or deterioration repaired or restored.

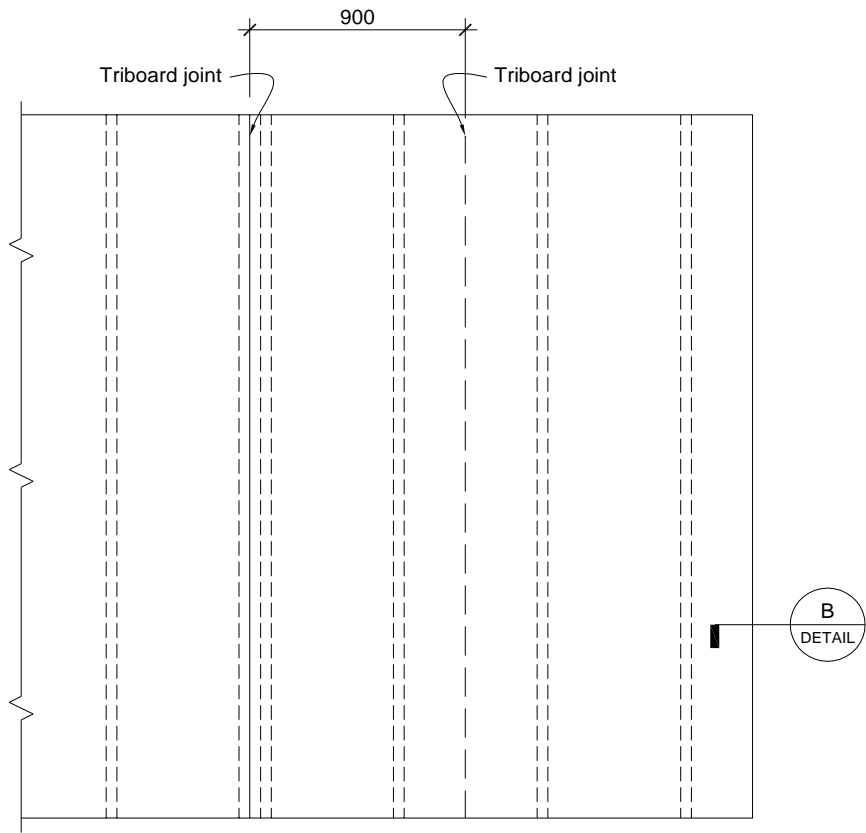

PANEL ELEVATION

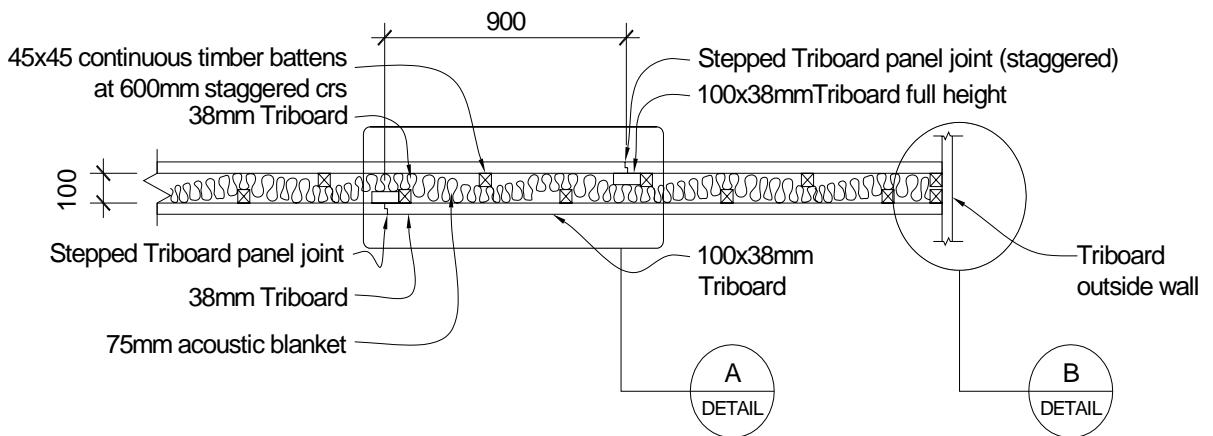

PLAN SECTION

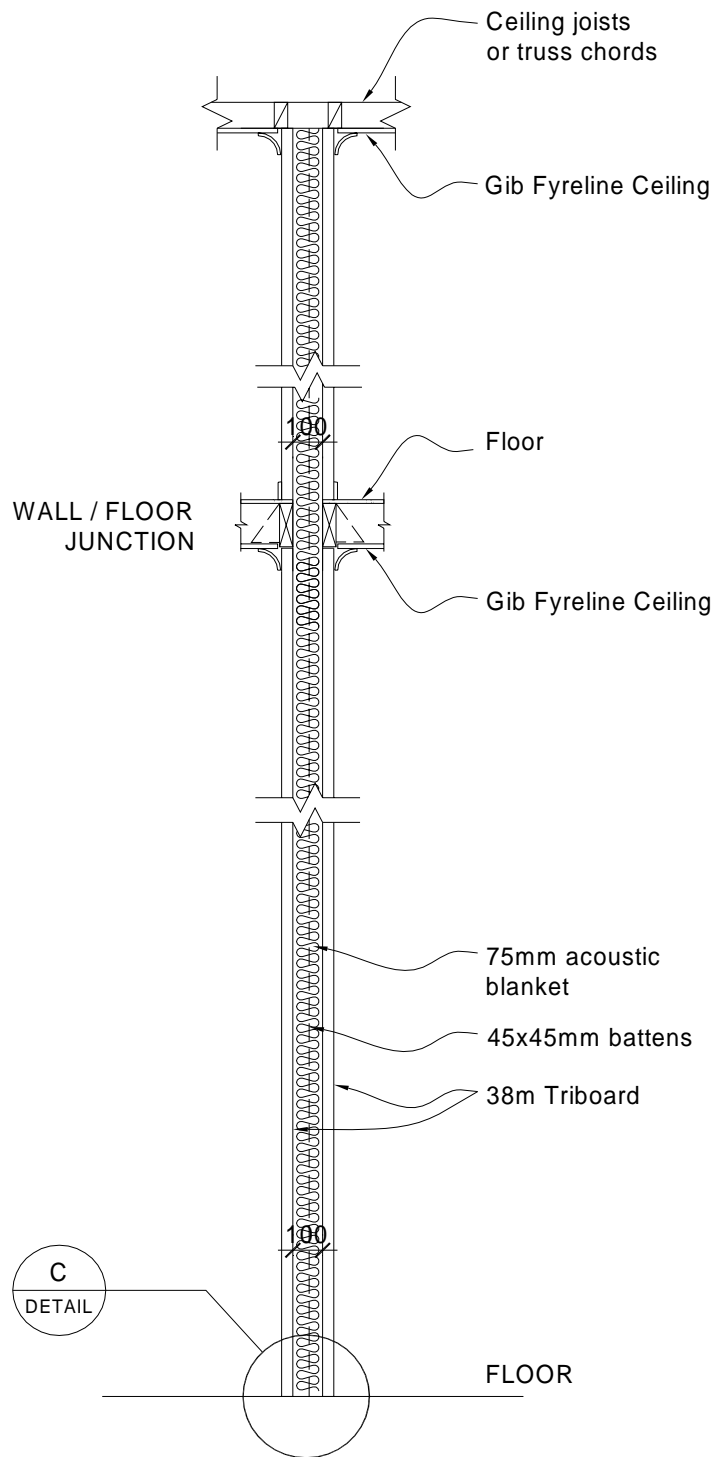

VERTICAL SECTION

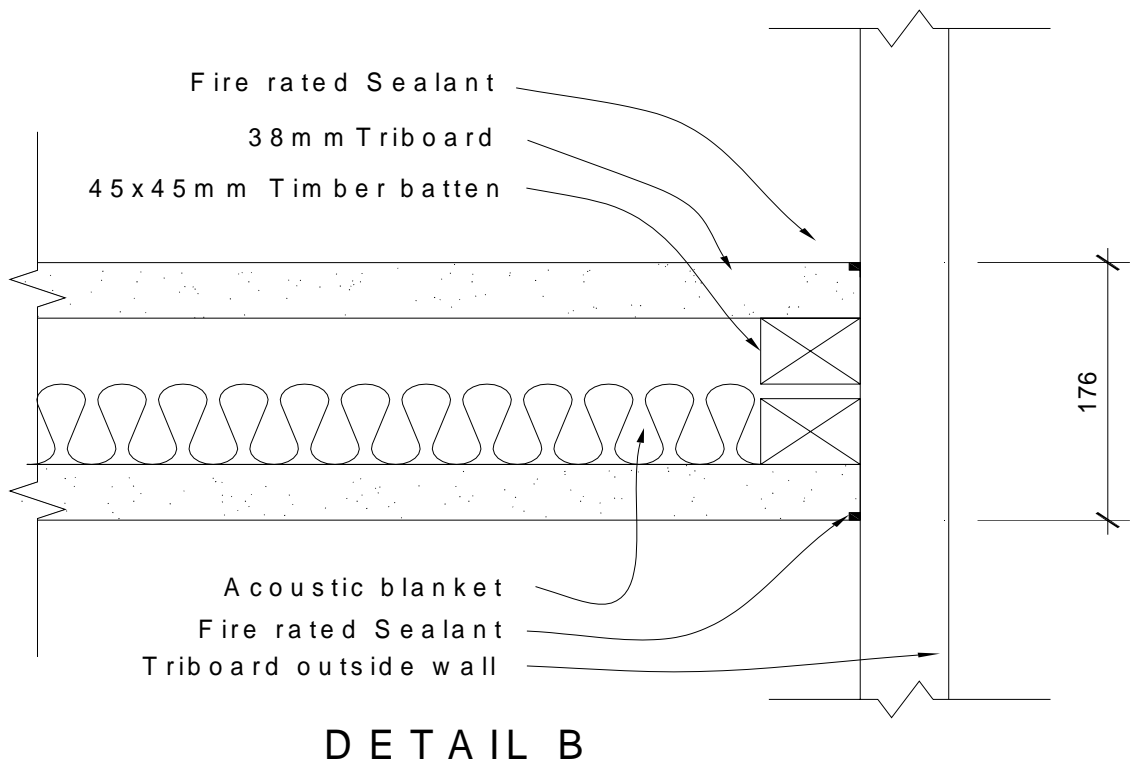
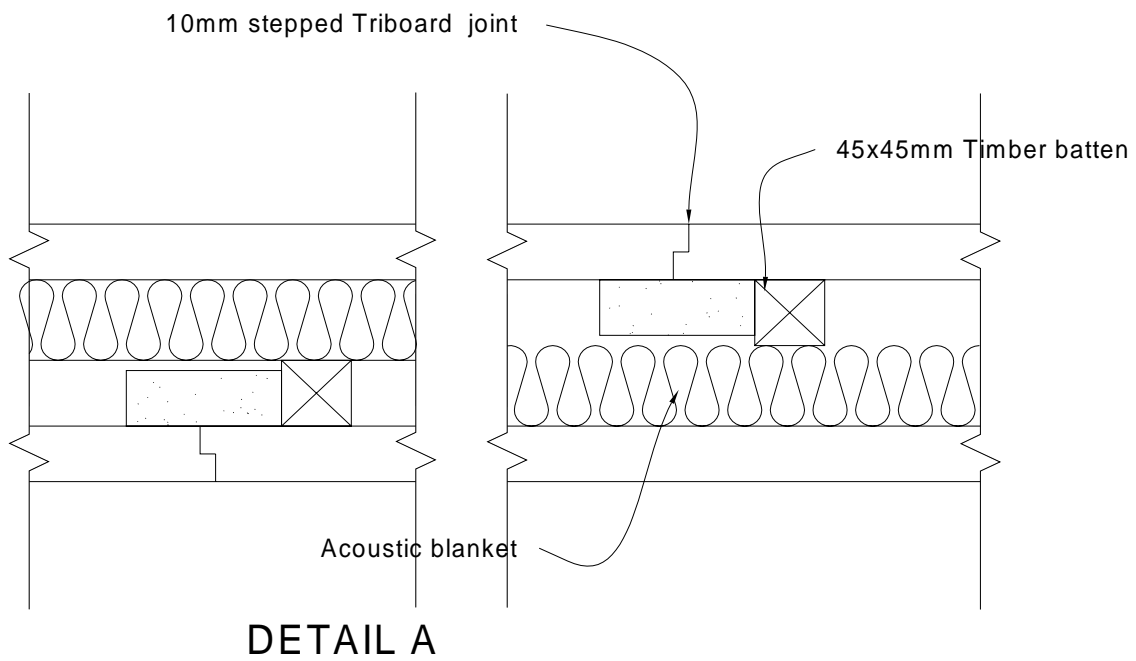

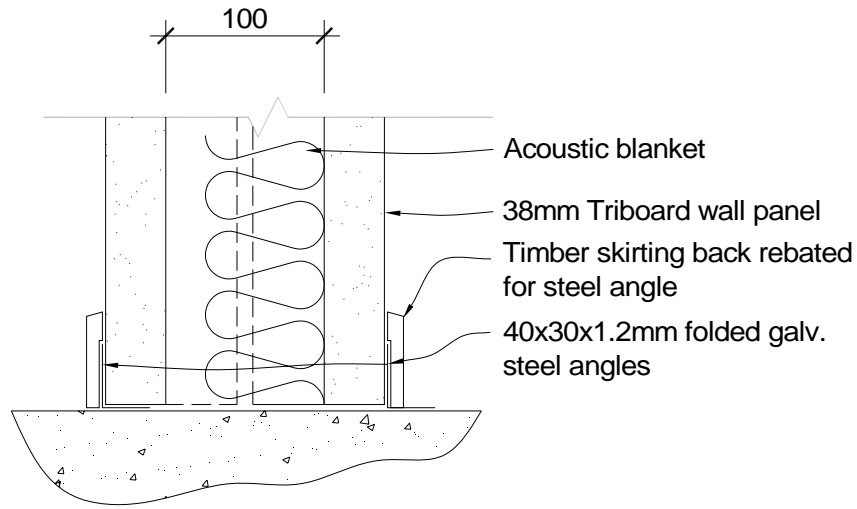

DETAIL C

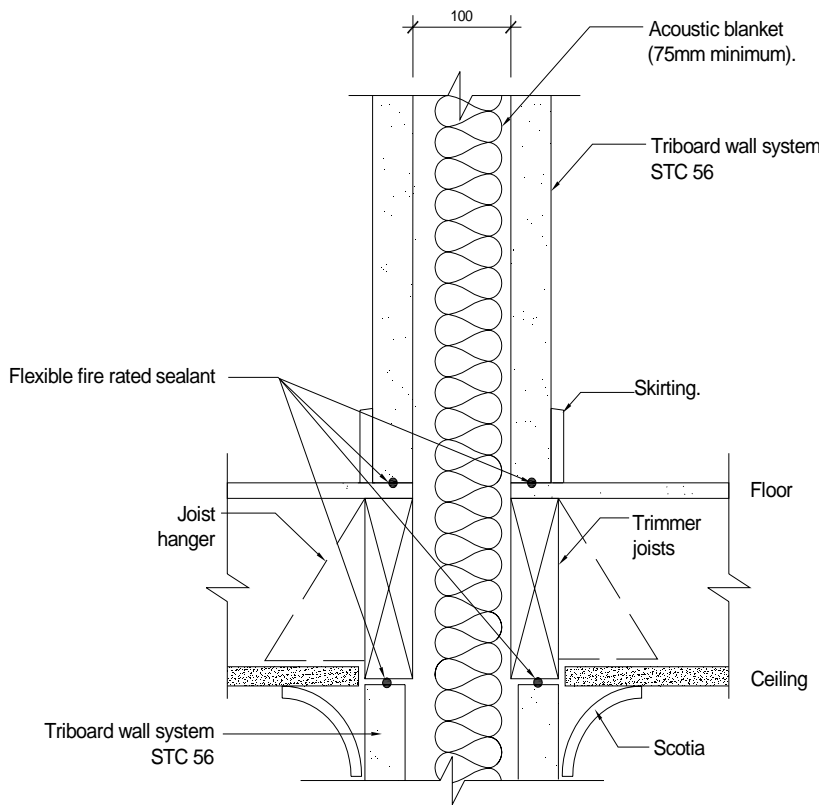

Wall / Floor Junction

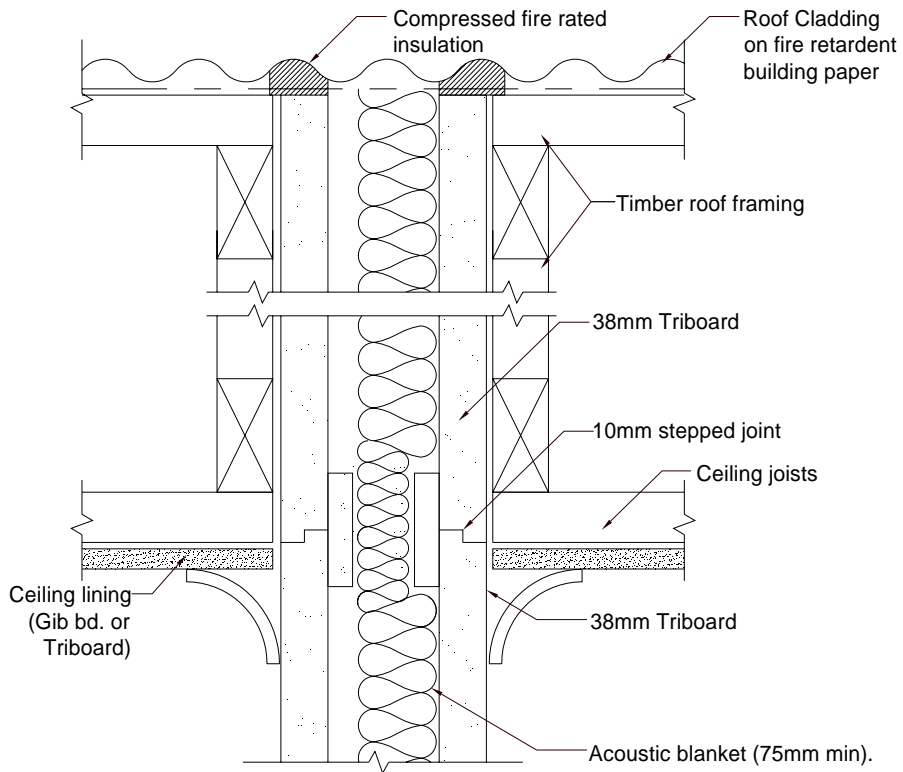

T i m b e r C e i l i n g

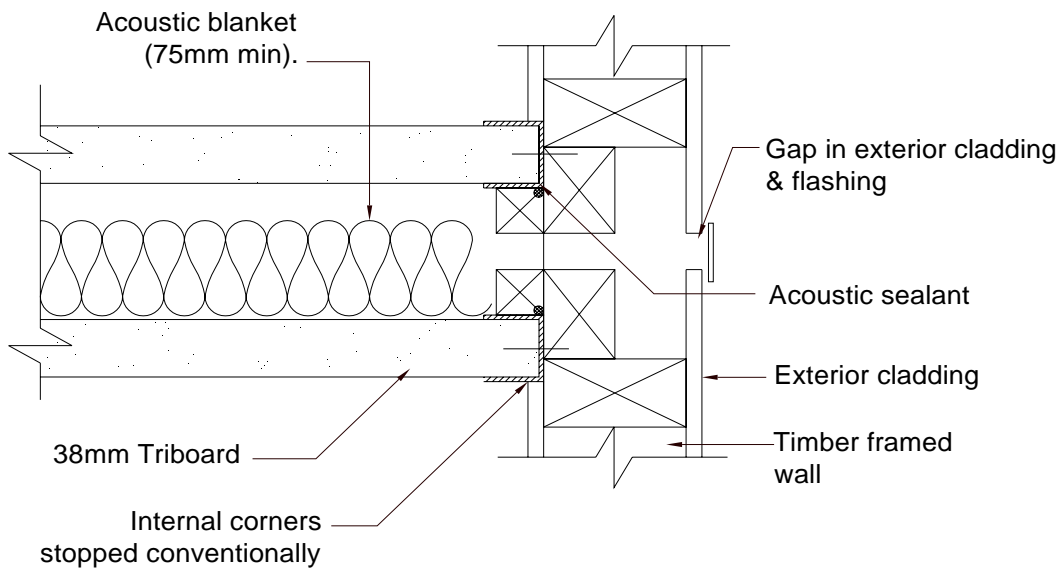

T i m b e r W a l l

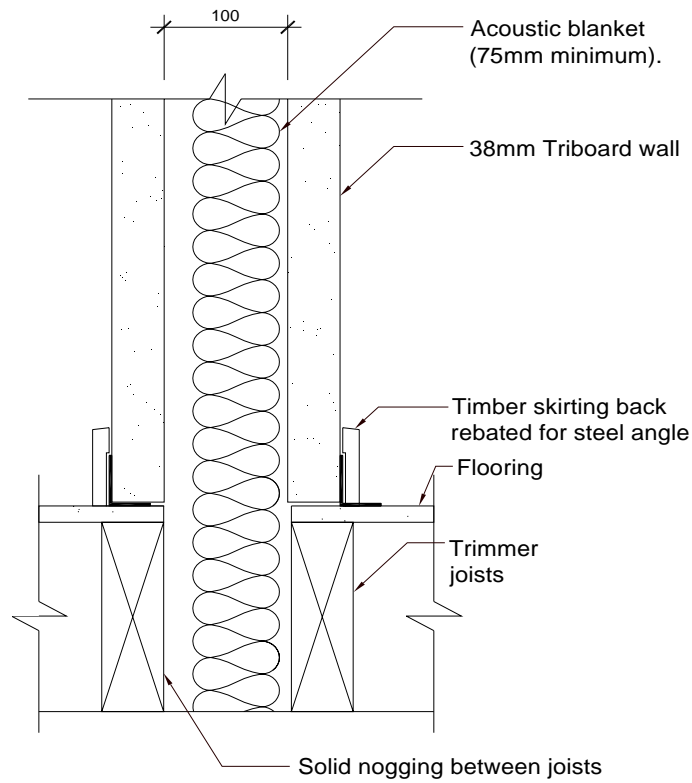

T i m b e r F l o o r i n g

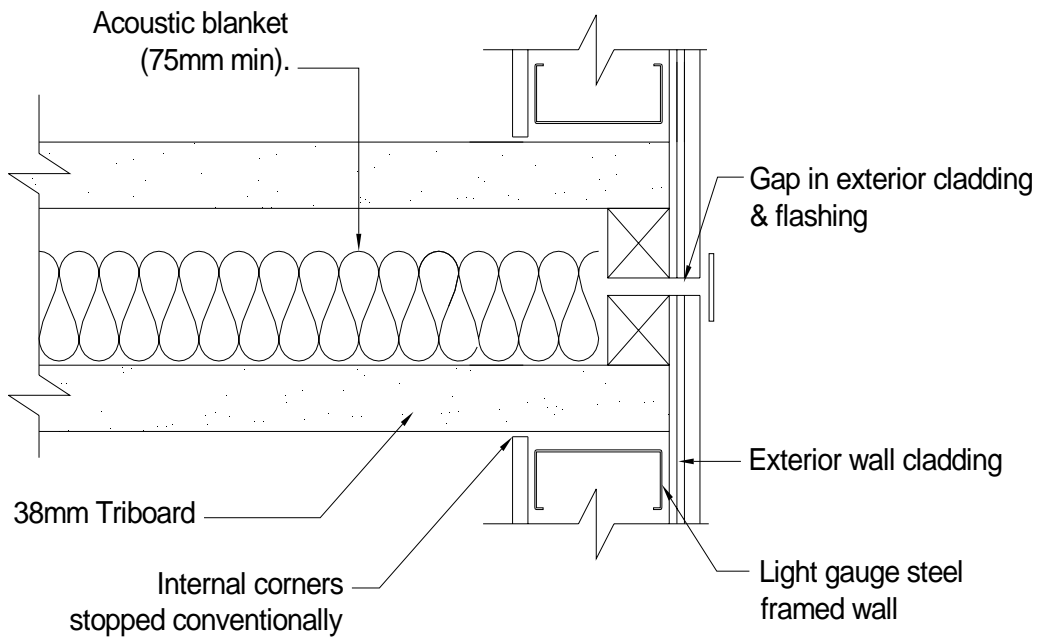

S t e e l W a l l

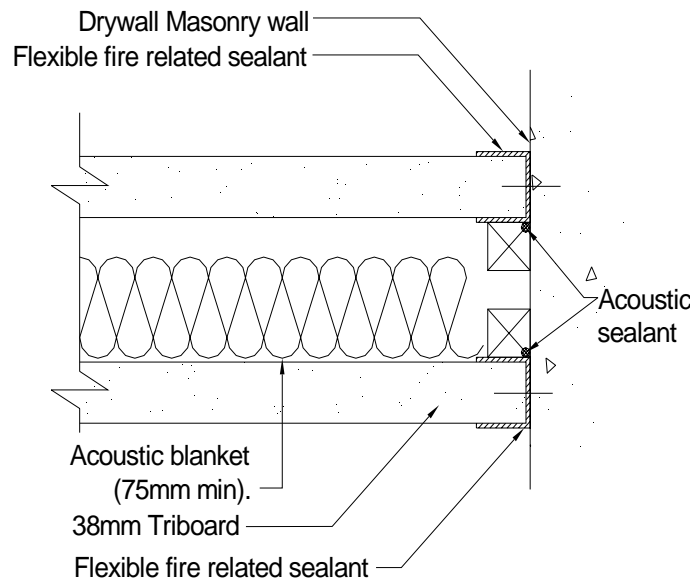

Concrete Wall

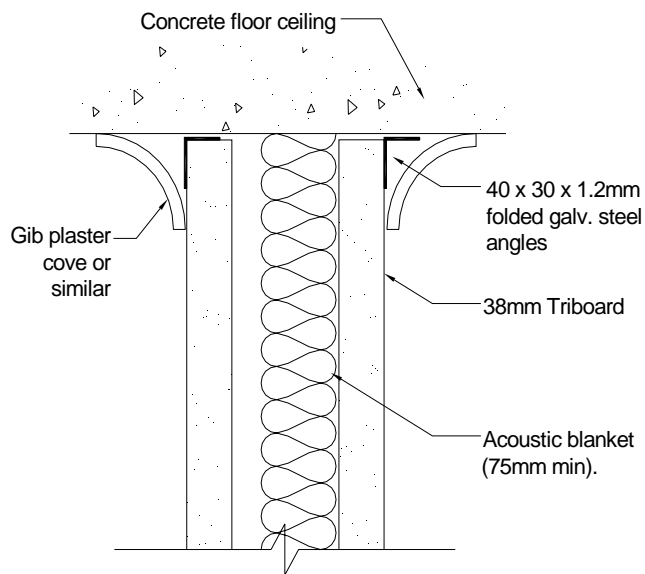

Concrete Ceiling

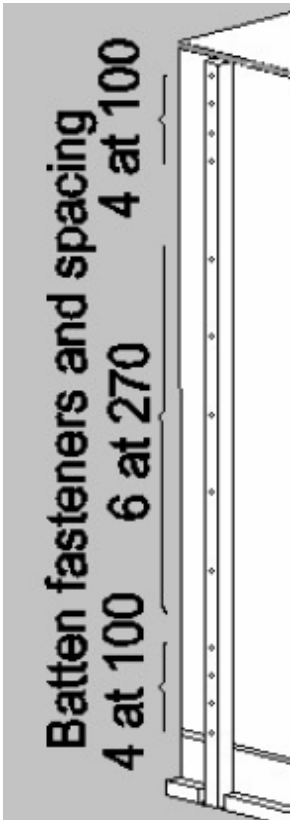

Safe work practices

Health and safety precautions must be taken when working with heavy and large products such as Triboard panels.

The full size Triboard panels are large and heavy, weighing approx 260kg each. Cut panels and pieces can also be awkward and heavy to lift.

Appropriate manual lifting and handling techniques must be developed in accordance with guidelines published by the Department of Labour or Occupational Health & Safety New Zealand.

If lifting machinery such as fork-lifts are used, appropriate training and safety standards must be developed in accordance with guidelines published by the Department of Labour or Occupational Health & Safety New Zealand.

Health and safety precautions must be taken when working with all wood products.

- Wood dust is classified as a known carcinogen. Repeated inhalation of wood dust over many years may cause nasal cancer.
- Wood dust may cause sensitisation resulting in asthma and result in dermatitis by skin contact.
- Exposure to wood dust and/or formaldehyde may cause irritation to the eyes, respiratory system and skin.
- Formaldehyde emissions from Triboard meet the E1 class when tested in accordance with AS/NZS 4266.16:2004. Formaldehyde is classified as a probable carcinogen.
- Storage areas containing large quantities of Triboard must be adequately ventilated.
- Work areas must be well ventilated and kept clean. Sawing, sanding and machining equipment must be fitted with dust extractors to ensure that dust levels are kept within standards laid down by Occupational Health & Safety New Zealand. If not, a dust mask conforming to AS/NZS 1715 and AS/NZS 1716 and eye protection conforming to AS/NZS 1337 must be worn.
- Offcuts, shavings and dust must be disposed of in a manner that avoids the generation of dust in accordance with the requirements of local waste authorities.
- In end use applications, all Triboard surfaces exposed to occupied space must be sealed.

Refer to Material Safety Data Sheet available from either JNL Triboard Mill or by visiting our website www.triboard.com. Reference can also be made to *Working Safely with Wood Panel Products* published by the Department of Labour, Occupational Safety and Health New Zealand, or *Home Health Facts About Formaldehyde in Wood Composite Products* published by the New Zealand Ministry of Health and BRANZ, available from Juken New Zealand Ltd.

Triboard handling and storage

- Prior to cutting, Triboard panels must be conditioned to ensure that they reach their moisture equilibrium before fixing to ceilings, floors or walls. This can be done by putting the panels into fillet to allow air circulation around both sides of the panel for a minimum of 24 hours.
- Avoid damage to the faces and edges of Triboard panels.
- Keep Triboard panels clean in order to avoid stains.
- Always stack Triboard panels horizontally, supported by gluts at maximum 1200mm centres laid on a flat level and dry surface.
- Triboard panels must be protected from direct sunlight whilst in storage in order to minimise warping of the panels.
- For short term storage on site, protect Triboard panels from direct exposure to weather with the use of tarpaulins or similar.
- To prevent moisture build up under covers, ensure there is proper air circulation around the pack of Triboard panels.
- Triboard panels should be kept dry at all times.

Related documents

- BRANZ Fire test report FR 3812.
- BRANZ Fire test report FR 1659.
- Auckland UniServices Limited sound test report # 9220.86.
- AS 1530.4 Methods of fire tests on building materials, components and structures – Fire resistance tests of elements of building construction.
- NZS 3101:2006 Concrete Structures Standard.
- NZS 3602:2003 Timber and wood-based products for use in buildings.
- NZS 3603:1993 Timber Structures Standard.
- NZS 3604:1999 Timber Framed buildings.
- New Zealand Building Code Handbook Dept of Building and Housing, Third edition May 2007.
- The Building Regulations 1992 up to and including June 2007 amendments.
- Triboard Construction Manual for New Zealand.
- BRANZ Appraisal No. 481 (2005) in respect of the Triboard Construction System.

Exclusion of Liability

The manufacturer (Juken New Zealand Ltd) accepts no responsibility for any loss, damage or claims which may arise (including without limitation, claims in negligence) through the use or installation of the Triboard product in a manner inconsistent with this design and construction manual (“the Manual”).

The information contained in the Manual is provided as a guide only. The manufacturer of Triboard provides this information in its capacity as manufacturer only. The responsibility of following and adhering to the specifications in this Manual is that of the user.

The specifications contained in this Manual relate to normal site conditions and other condition set out in this Manual. Individual site characteristics, conditions and circumstances may warrant changes to the specifications in this manual. The manufacturer is not liable or responsible in variations in the specifications made as a result of the circumstances of each site.



Aerial photo of Juken New Zealand – Triboard Mill

JUKEN NEW ZEALAND LTD – TRIBOARD MILL

Whangatane Drive
P. O. Box 153, Kaitaia, 0441, NZ.
Telephone: +64 (09) 408 0300
Facsimile: +64 (09) 408 9113
Website: www.triboard.com